

GUJARAT TECHNOLOGICAL UNIVERSITY**BE - SEMESTER-VIII(NEW) EXAMINATION – SUMMER 2019****Subject Code:2182002****Date:17/05/2019****Subject Name: Automated Manufacturing-II****Time:10:30 AM TO 01:00 PM****Total Marks: 70****Instructions:**

1. Attempt all questions.
2. Make suitable assumptions wherever necessary.
3. Figures to the right indicate full marks.

MARKS

- Q.1**
- | | | |
|-----|--|-----------|
| (a) | Define robot and its future application. | 03 |
| (b) | What is robot anatomy? Discuss with neat sketch, various joints in robot. | 04 |
| (c) | Consider Schematic of a 3-DOF articulated arm shown in figure 1. Using D-H notation Construct: 1) Set of robotic coordinate frame, 2) A table for joint parameter, 3) Each joint individual matrix | 07 |

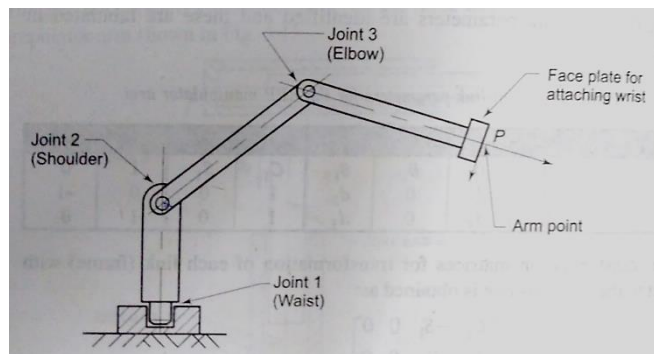

Figure 1.

- Q.2**
- | | | |
|-----|--|-----------|
| (a) | Evaluate “Accuracy is an absolute concept, repeatability is relative”. | 03 |
| (b) | Differentiate the forward kinematics and inverse kinematics. | 04 |
| (c) | What is CIM? Explain with neat sketch CIM wheel? | 07 |

OR

- | | | |
|-----|---|-----------|
| (c) | What is difference between powered lead through and manual lead through in robot programming? | 07 |
|-----|---|-----------|

- Q.3**
- | | | |
|-----|--|-----------|
| (a) | Evaluate “Load carrying capacity specified under the condition of robot’s arm is its weakest position”. | 03 |
| (b) | Briefly classify and describe various programming methods of robot. | 04 |
| (c) | Give suitable example of quality control in industry handled with the help of robotic vision system. Describe the set up and other requirements with the help of appropriate diagrams. | 07 |

OR

- Q.3**
- | | | |
|-----|--|-----------|
| (a) | Describe the various type of interpolation schemes use in robot programming. | 03 |
| (b) | With a neat sketch explain in details the Proximity and Range sensor and write down application. | 04 |
| (c) | Define the master production scheduling. Explain the factors that need to be taken into account while developing master production schedule. | 07 |

- Q.4**
- | | | |
|-----|--|-----------|
| (a) | Briefly describe the concept of Opitz classification and coding system. | 03 |
| (b) | Discuss in brief the significance of trajectory planning of robot manipulator with suitable example. | 04 |
| (c) | Explain with the help of block diagram various inputs of MRP (Material Requirement Planning). | 07 |

OR

- Q.4** (a) Briefly describe the concept of PFA classification and coding system. **03**
(b) Give classification of robot end effectors. Draw neat schematic diagrams of any two mechanisms used in robot end effectors. **04**
(c) Explain the working principle of Holier Method in deciding the sequence of machines and material flow. **07**

- Q.5** (a) Explain concept of image acquisition and processing . **03**
(b) Explain the following term in GT: (1) mono code (2) poly code (3) mixed code. **04**
(c) Bring out the importance of D-H matrix used to represent robotic configurations in forward kinematics. Describe joint-link parameters used for D-H representation and necessary motions to transform from one reference frame to the next one. **07**

OR

- Q.5** (a) Discuss and describe any one technology used in vehicle guidance for Automated Guided Vehicle System (AGVS) in FMS. **03**
(b) Difference between FMC and FMS **04**
(c) Apply the rank order clustering technique to the part machine incidence matrix shown in Table 1. to identify logical part families and machine groups. The parts are identified by letters and machine are identified by numbers. **07**

Part No.						
Machine. No.	A	B	C	D	E	F
1	1				1	
2				1		1
3	1	1				
4			1	1		
5		1			1	
6			1	1		1

Table 1.
